

Power Barrier Add-on KIT (0482) for LogiCO2 Safety System



TECHNICAL DATA

Power supply:	24V DC, from the alarm system
Current consumption:	2 x 17 mA (Supply from two power supplies)
Humidity:	0-90% non-condensing
Approval:	CE: Emission tests according SS-EN 61000-6-3 and the immunity tests according to SS-EN 61000-6-2.
Ambient temperature:	0 to +40°C (+32°F to +102°F)
Dimensions (LxWxD):	90 x 161 x 38 mm / 3.5" x 6.3" x 1.5"
Ingress protection:	IP54 according to TÜV, IP44 according to UL

FUNCTION

The LogiCO2 Power Barrier enables you to connect multiple power supplies (up to eight) in one system. Each power supply has an output of 1 A insuring that the power limits are not exceeded on the cables and connectors in each loop. The Power Barriers still allows each separated sensor to communicate with the Central Unit.

Power to the Power Barrier is supplied from the safety system.

INDICATORS

The upper green LED indicates that the left cable is connected to power. The lower green LED indicates that the right cable is connected to power. Both LEDs must be on for proper function.



ASSEMBLY

If the cover of the Power Barrier needs to be removed, please observe the following order of screw reassembly.

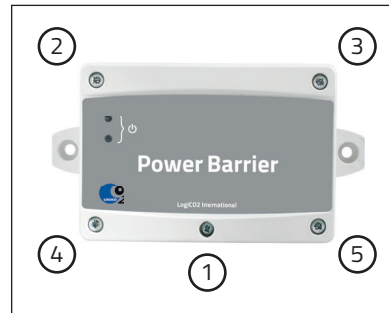

ORDERING EXAMPLE

Item code	Description
0482	Power Barrier for CO2 Safety System

Power Barrier Add-on KIT (0482) for LogiCO2 Safety System



INSTALLATION

In the example below one Central Unit is communicating with both Mk9 and Mk10 CO2 Sensors. Three different power supplies are connected to the system, but they are galvanically separated by the Power Barriers.

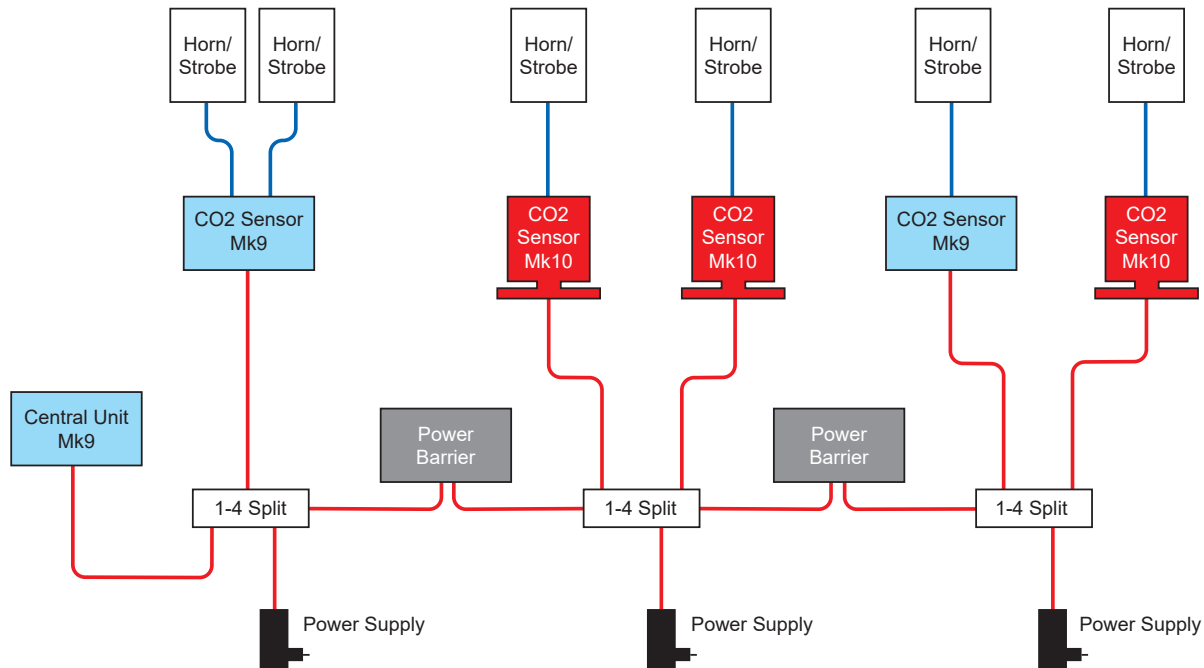

POWER CONSUMPTION

One power supply has an output of 1 A (1000 mA). Use this list to calculate if you need a power barrier.

	Product	mA (Peak)
	CO2 MK9 Detector SET 4 A	177
	CO2 Alert Mk10 Detector SET 2 A	323
	CO2 Sensor Mk9	75
	Central Unit Mk9	35
	CO2 Sensor Mk10	297
	O2 Sensor Mk9	42
	Sniffer	16
	Power Barrier	17
	Horn/Strobe LED Amber	80

	Product	mA (Peak)
	Horn/Strobe Xenon	193
	Flash-24-R	127
	Traffic Light	410
	Horn/Strobe Outdoor	198
	Siren-24-R	31
	Remote Connection Box (relay)	20
	Remote Connection Box (reset button)	45
	Safe Mode Box and Shut off Valve	196